

CHOOOLS CONSULTING SERVICE

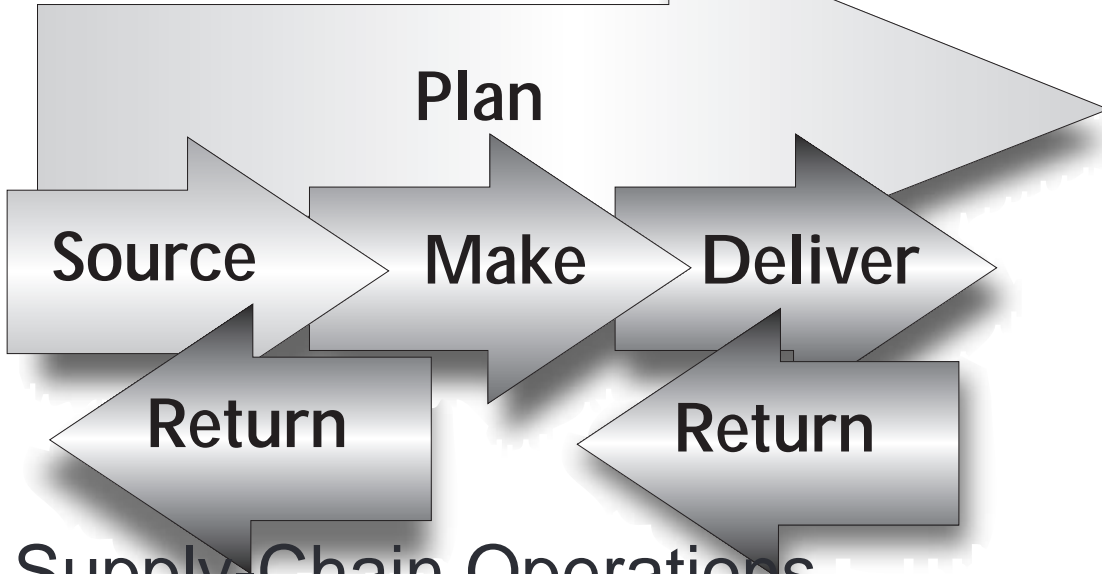

Supply-Chain Operations
By Chools Consulting Service
Reference-model

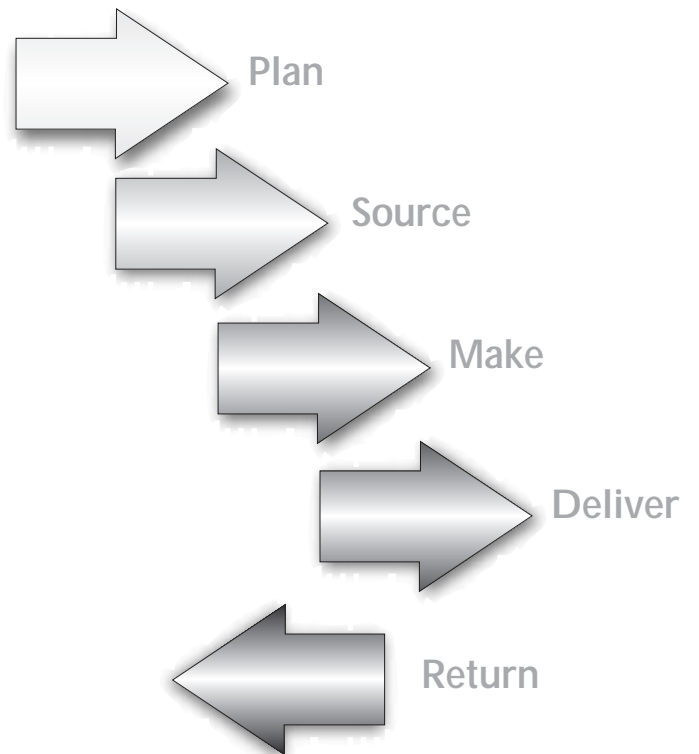

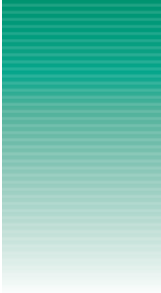

Supply-Chain Operations Reference-model

Overview Version 5.0

CONTENTS

- ▶ What is a Process Reference Model?
- ▶ Model Scope and Structure
- ▶ Applying the Model
 - The Concept of Configurability
 - Configuring Supply-Chain Threads
 - Developing Process Maps
- ▶ Summary

The Supply Chain Operations Reference-model (SCOR) has been developed and endorsed by the CHOOIS Supply-Chain , an independent not-for-profit corporation, as the cross-industry standard for supply-chain management.



What Is a Process Reference Model?

Process reference models integrate the well-known concepts of business process reengineering, benchmarking, and process measurement into a cross-functional framework.

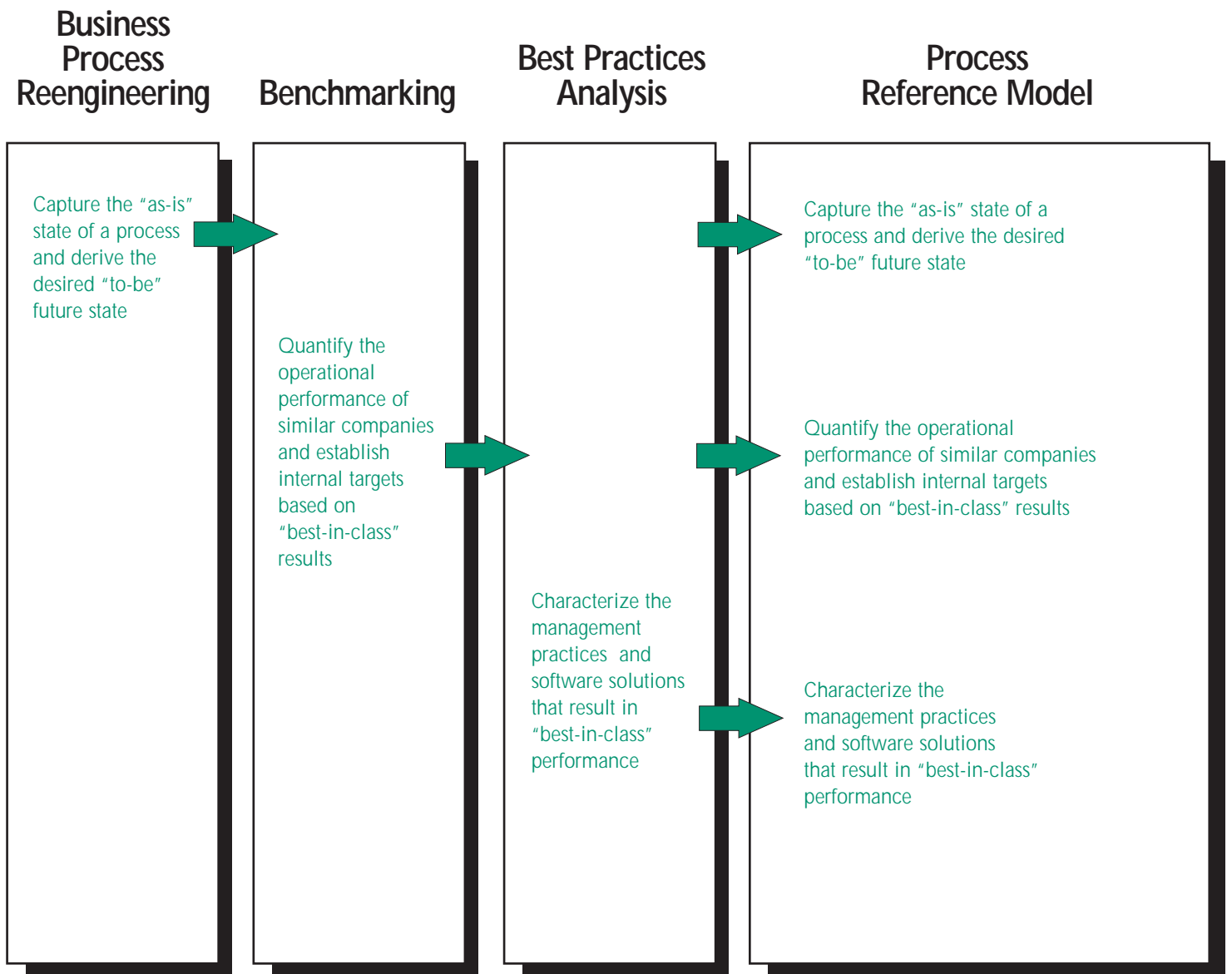

A Process Reference Model Contains:

- Standard descriptions of management processes
- A framework of relationships among the standard processes
- Standard metrics to measure process performance
- Management practices that produce best-in-class performance
- Standard alignment to features and functionality

Once a Complex Management Process is Captured in Standard Process Reference Model Form, It can Be:

- Implemented purposefully to achieve competitive advantage
- Described unambiguously and communicated
- Measured, managed, and controlled
- Tuned and re-tuned to a specific purpose

► **A Process Reference Model
Becomes a Powerful Tool in the Hands
of Management**

The Boundaries of Any Model Must Be Carefully Defined

“From your supplier’s supplier to your customer’s customer”

SCOR spans:

- All customer interactions, from order entry through paid invoice
- All product (physical material and service) transactions, from your supplier’s supplier to your customer’s customer, including equipment, supplies, spare parts, bulk product, software, etc.
- All market interactions, from the understanding of aggregate demand to the fulfillment of each order

SCOR does not attempt to describe every business process or activity, including:

- Sales and marketing (demand generation)
- Research and technology development
- Product development
- Some elements of post-delivery customer support

Links can be made to processes not included within the model’s scope, such as product development, and some are noted in SCOR.

SCOR assumes but does not explicitly address:

- Training
- Quality
- Information Technology (IT)
- Administration (non SCM)

SCOR is Based on Five Distinct Management Processes

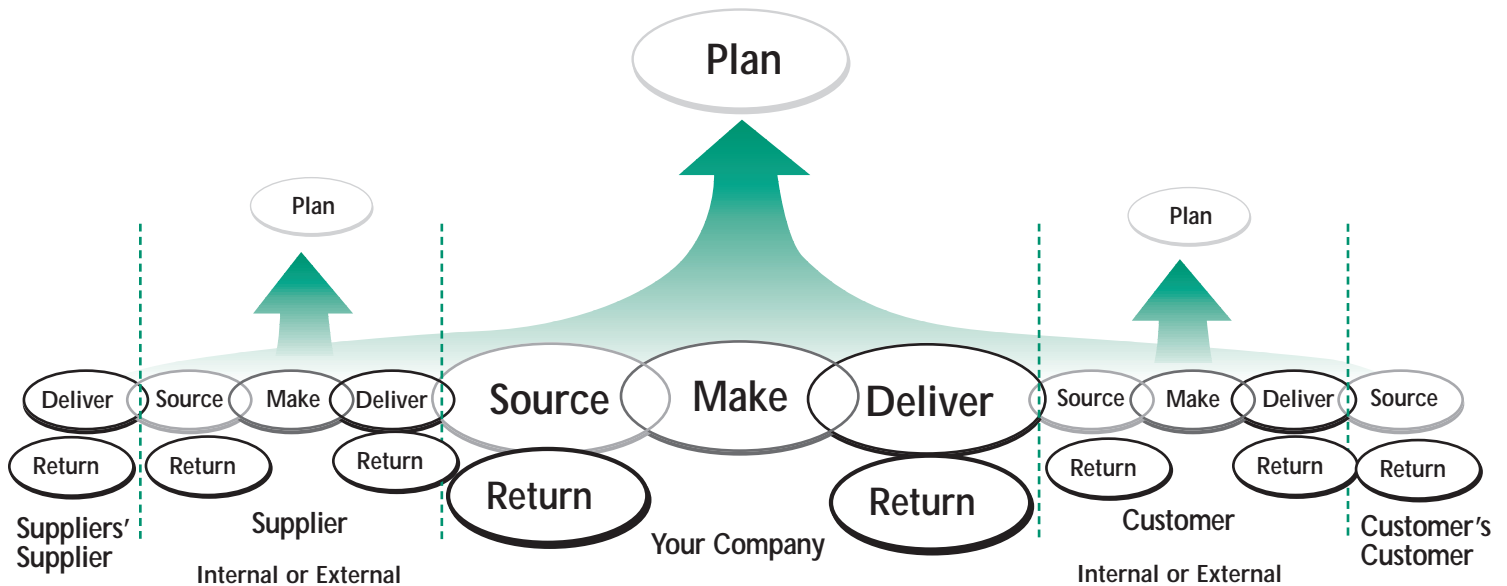

Scope of SCOR Processes

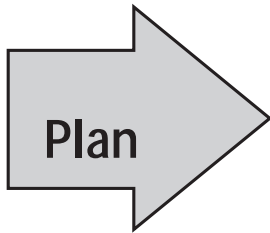

Demand/Supply Planning and Management

- ▶ Balance resources with requirements and establish/communicate plans for the whole supply chain, including Return, and the execution processes of Source, Make, and Deliver.
- ▶ Management of business rules, supply chain performance, data collection, inventory, capital assets, transportation, planning configuration, and regulatory requirements and compliance.
- ▶ Align the supply chain unit plan with the financial plan.

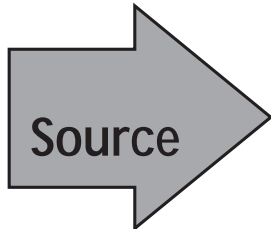

Sourcing Stocked, Make-to-Order, and Engineer-to-Order Product

- ▶ Schedule deliveries; receive, verify, and transfer product; and authorize supplier payments.
- ▶ Identify and select supply sources when not predetermined, as for engineer-to-order product.
- ▶ Manage business rules, assess supplier performance, and maintain data.
- ▶ Manage inventory, capital assets, incoming product, supplier network, import/export requirements, and supplier agreements.

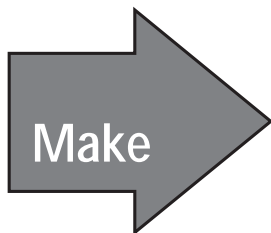

Make-to-Stock, Make-to-Order, and Engineer-to-Order Production Execution

- ▶ Schedule production activities, issue product, produce and test, package, stage product, and release product to deliver.
- ▶ Finalize engineering for engineer-to-order product.
- ▶ Manage rules, performance, data, in-process products (WIP), equipment and facilities, transportation, production network, and regulatory compliance for production.

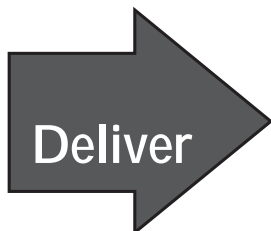

Order, Warehouse, Transportation, and Installation Management for Stocked, Make-to-Order, and Engineer-to-Order Product

- ▶ All order management steps from processing customer inquiries and quotes to routing shipments and selecting carriers.
- ▶ Warehouse management from receiving and picking product to load and ship product.
- ▶ Receive and verify product at customer site and install, if necessary.
- ▶ Invoicing customer.
- ▶ Manage Deliver business rules, performance, information, finished product inventories, capital assets, transportation, product life cycle, and import/export requirements.

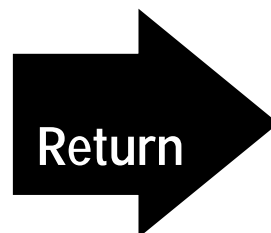

Return of Raw Materials (to Supplier) and Receipt of Returns of Finished Goods (from Customer), including Defective Products, MRO Products, and Excess Products

- ▶ All return defective product steps from authorizing return; scheduling product return; receiving, verifying, and disposition of defective product; and return replacement or credit.
- ▶ Return MRO product steps from authorizing and scheduling return, determining product condition, transferring product, verifying product condition, disposition, and request return authorization.
- ▶ Return excess product steps including identifying excess inventory, scheduling shipment, receiving returns, approving request authorization, receiving excess product return in Source, verifying excess, and recover and disposition of excess product.
- ▶ Manage Return business rules, performance, data collection, return inventory, capital assets, transportation, network configuration, and regulatory requirements and compliance.

A Process Reference Model Differs from Classic Process Decomposition Models

SCOR is a process reference model that provides a language for communicating among supply-chain partners

- ▶ Process decomposition models are developed to address one specific configuration of process elements

Level

Contains:

1

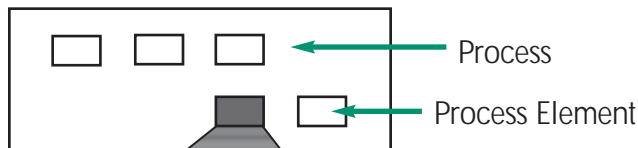

2

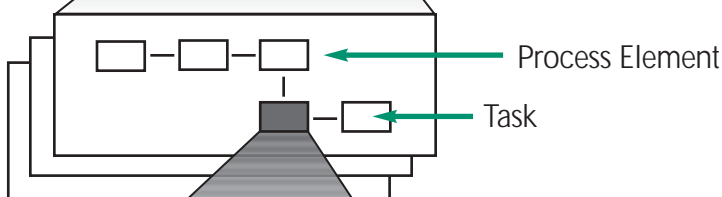

3

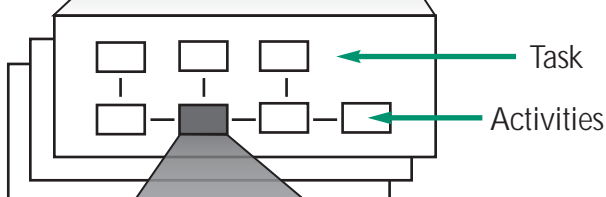

4









- ▶ Provide a balanced horizontal (cross-process) and vertical (hierarchical) view

- ▶ Designed to be (re)configurable

- ▶ Used to represent many different configurations of a similar process

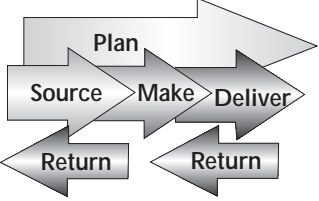
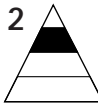
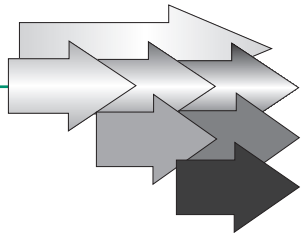
- ▶ Aggregate a series of hierarchical process models

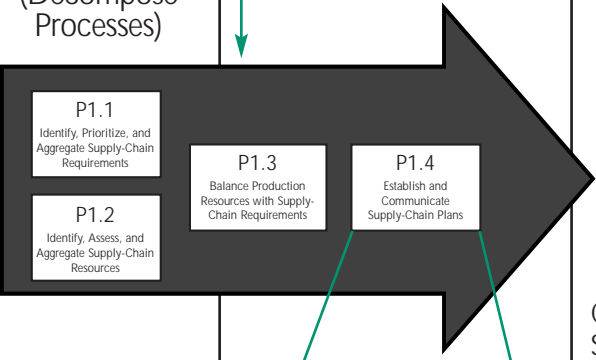
SCOR Contains Three Levels of Process Detail

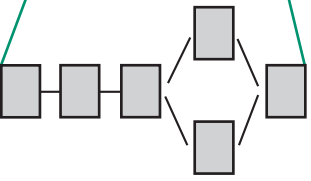
		Level			
		#	Description	Schematic	Comments
Supply-Chain Operations Reference-model 	1	 Top Level (Process Types)		Level 1 defines the scope and content for the Supply Chain Operations Reference-model. Here basis of competition performance targets are set.	
	2	 Configuration Level (Process Categories)		A company's supply chain can be "configured-to-order" at Level 2 from 30 core "process categories." Companies implement their operations strategy through the configuration they choose for their supply chain.	
	3	 Process Element Level (Decompose Processes)		Level 3 defines a company's ability to compete successfully in its chosen markets, and consists of: <ul style="list-style-type: none"> • Process element definitions • Process element information inputs, and outputs • Process performance metrics • Best practices, where applicable • System capabilities required to support best practices • Systems/tools Companies "fine tune" their Operations Strategy at Level 3.	
	4	 Implementation Level (Decompose Process Elements)		Companies implement specific supply-chain management practices at this level. Level 4 defines practices to achieve competitive advantage and to adapt to changing business conditions.	

Process Categories

Defined by the Relationship Between a SCOR Process and a Process Type

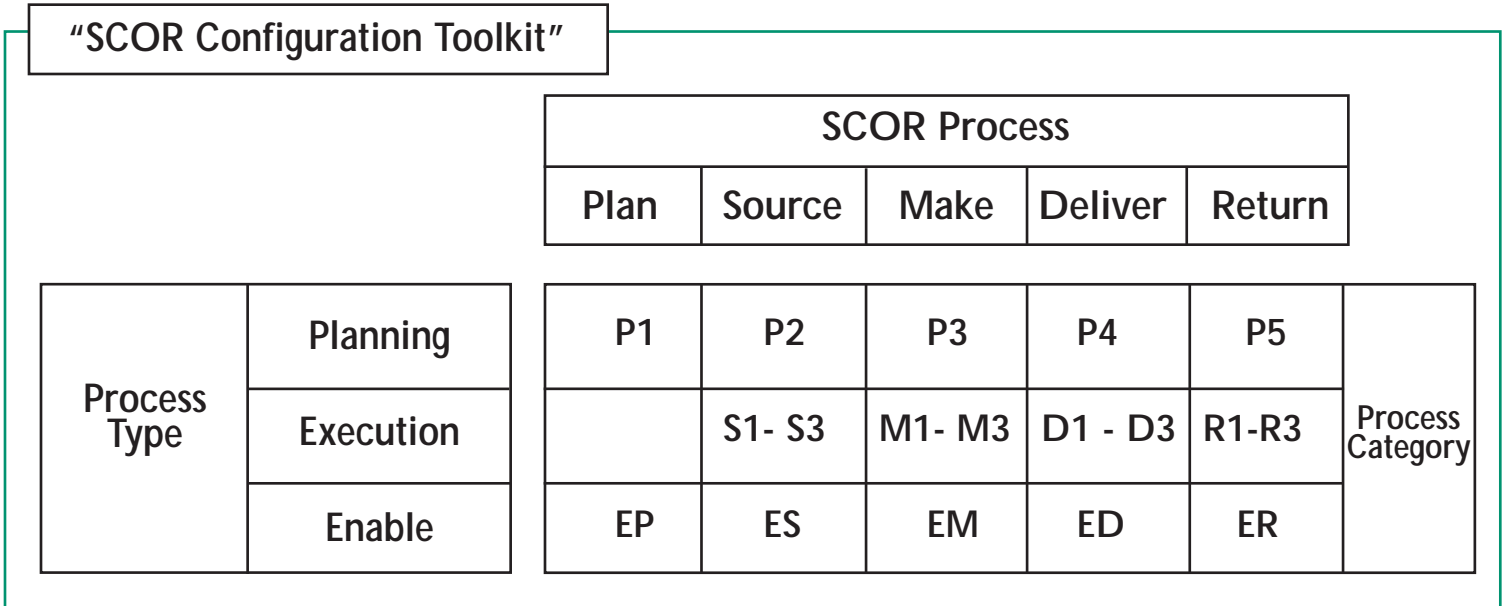

Practitioners select appropriate process categories from the SCOR configuration toolkit to represent their supply-chain configuration(s).

Level 1 Process Definitions

SCOR Is Based on Five Core Management Processes

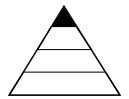

SCOR Process	Definitions
Plan	Processes that balance aggregate demand and supply to develop a course of action which best meets sourcing, production and delivery requirements
Source	Processes that procure goods and services to meet planned or actual demand
Make	Processes that transform product to a finished state to meet planned or actual demand
Deliver	Processes that provide finished goods and services to meet planned or actual demand, typically including order management, transportation management, and distribution management
Return	Processes associated with returning or receiving returned products for any reason. These processes extend into post-delivery customer support

Level 1 Performance Metrics

Performance Attribute	Customer-Facing			Internal-Facing	
	Reliability	Responsiveness	Flexibility	Cost	Assets
Delivery performance	✓				
Fill Rate	✓				
Perfect order fulfillment	✓				
Order fulfillment lead time		✓			
Supply-chain response time			✓		
Production flexibility			✓		
Supply chain management cost				✓	
Cost of goods sold				✓	
Value-added productivity				✓	
Warranty cost or returns processing cost				✓	
Cash-to-cash cycle time					✓
Inventory days of supply					✓
Asset turns					✓

At Level 2, Each SCOR Process Can Be Further Described by Process Type

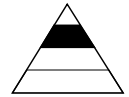

SCOR Process Type	Characteristics
Planning	<p>A process that aligns expected resources to meet expected demand requirements. Planning processes:</p> <ul style="list-style-type: none"> • Balance aggregated demand and supply • Consider consistent planning horizon • (Generally) occur at regular, periodic intervals • Can contribute to supply-chain response time
Execution	<p>A process triggered by planned or actual demand that changes the state of material goods. Execution processes:</p> <ul style="list-style-type: none"> • Generally involve - <ol style="list-style-type: none"> 1. Scheduling/sequencing 2. Transforming product, and/or 3. Moving product to the next process • Can contribute to the order fulfillment cycle time
Enable	<p>A process that prepares, maintains, or manages information or relationships on which planning and execution processes rely</p>

SCOR Version 5.0 Level 2 Toolkit Has 30 Process Categories

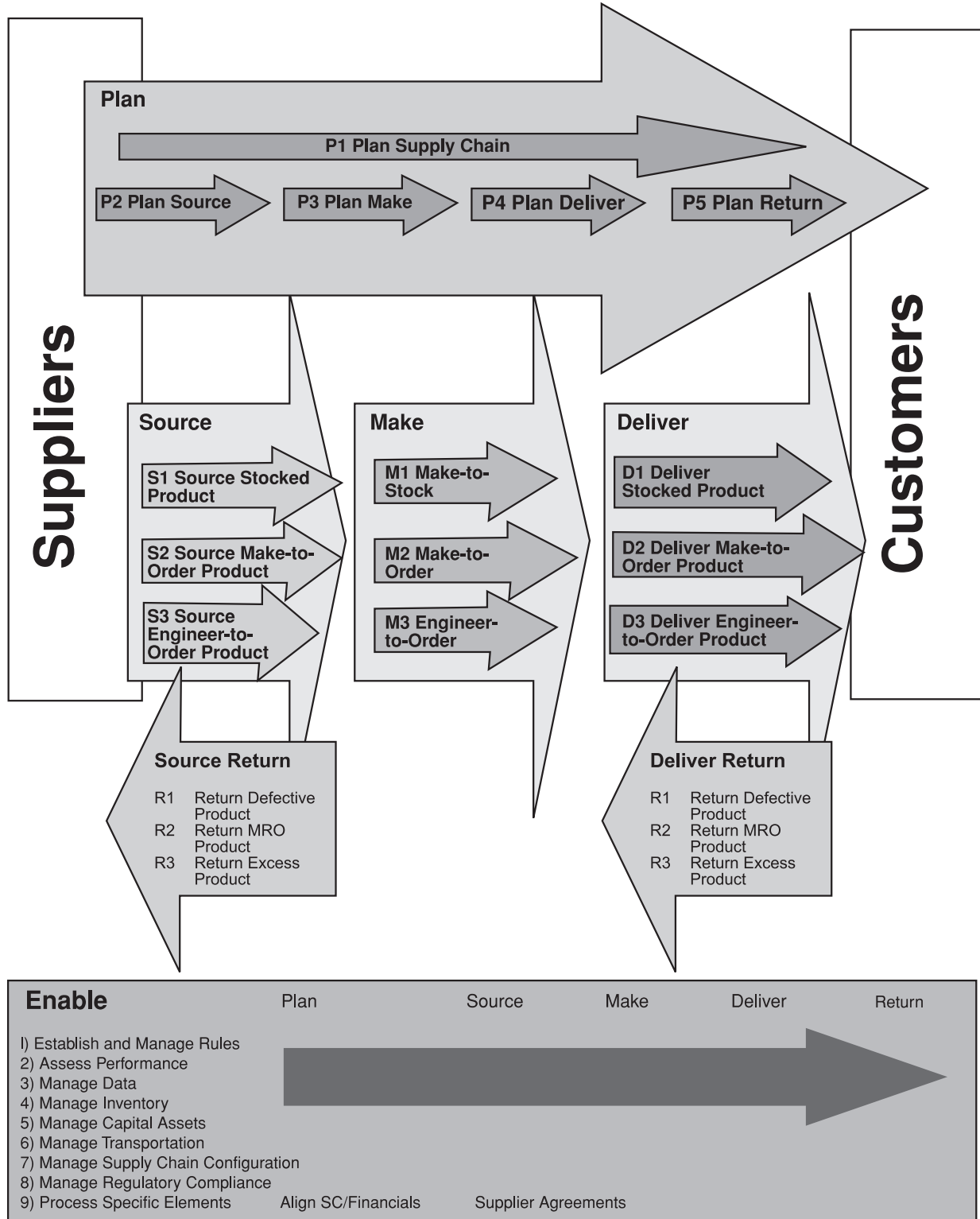
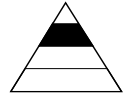

SCOR Level 3

Presents Detailed Process Element Information for Each Level 2 Process Category

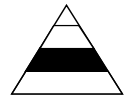

S1 Source Stocked Product

- ▶ Process flow
- ▶ Inputs and outputs
- ▶ Source of inputs
- ▶ Output destination

Level 3 Example — S1 Source Stocked Product

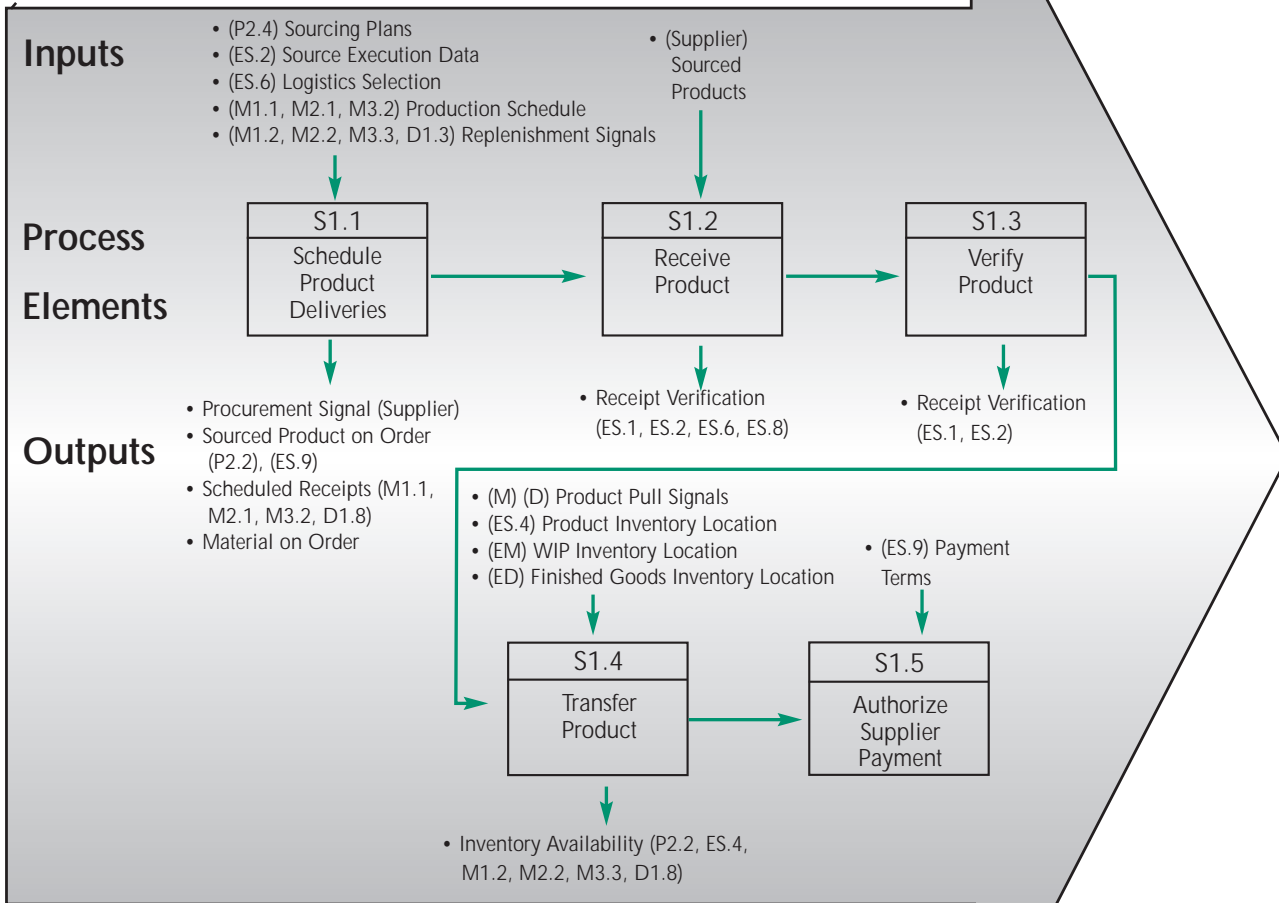

Inputs, outputs, and basic logic flow of process elements are captured.

An Example of SCOR Level 3 Process Element Logic Flow

Examples:

SCOR Level 3 Standard Process Element Definition, Performance Attributes and Accompanying Metrics

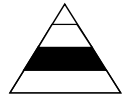

Process Element: Schedule Product Deliveries		Process Number: S1.1
Process Element Definition		
<p><i>Scheduling and managing the execution of the individual deliveries of product against an existing contract or purchase order. The requirements for product releases are determined based on the detailed sourcing plan or other types of product pull signals.</i></p>		
Performance Attributes	Metric	
Reliability	% Schedules Generated within Supplier's Lead Time % Schedules Changed within Supplier's Lead Time	
Responsiveness	Average Release Cycle of Changes	
Flexibility	Average Days per Schedule Change Average Days per Engineering Change	
Cost	Product Management and Planning Costs as a % of Product Acquisitions Costs	
Assets	None Identified	

SCOR Level 3 Best Practices and Features

Process Element: Schedule Product Deliveries		Process Number: S1.1
Best Practices	Features	
Utilize EDI transactions to reduce cycle time and costs	EDI interface for 830, 850, 856, and 862 transactions	
VMI agreements allow suppliers to manage (replenish) inventory	Supplier managed inventories with scheduling interfaces to external supplier systems	
Mechanical (Kanban) pull signals are used to notify suppliers of the need to deliver product	Electronic Kanban support	
Consignment agreements are used to reduce assets and cycle time while increasing the availability of critical items	Consignment inventory management	
Advanced ship notices allow for tight synchronization between SOURCE and MAKE processes	Blanket order support with scheduling interfaces to external supplier systems	

Implementation of Supply-Chain Management Practices within the Company Occurs at Level 4 (and below)

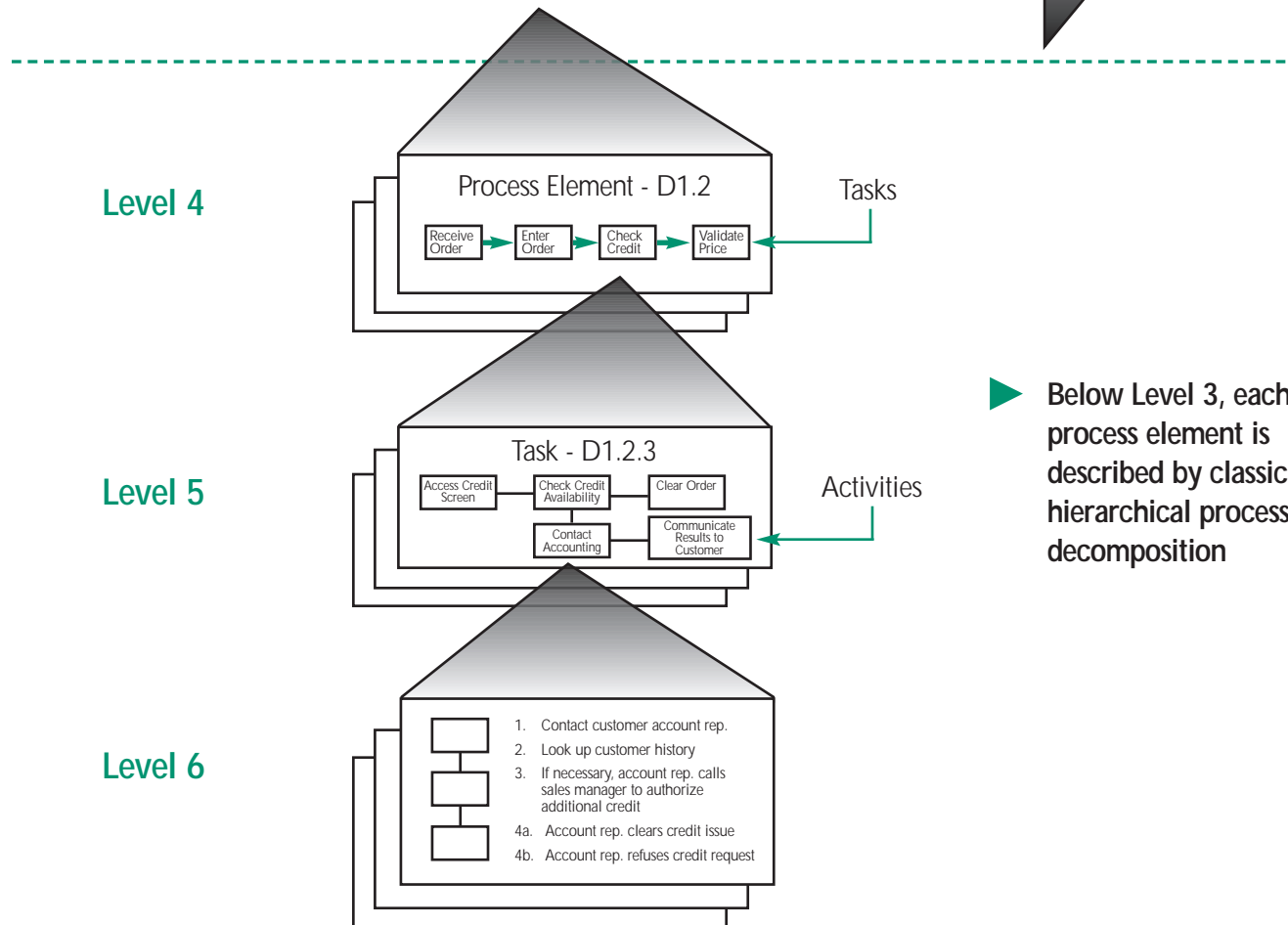
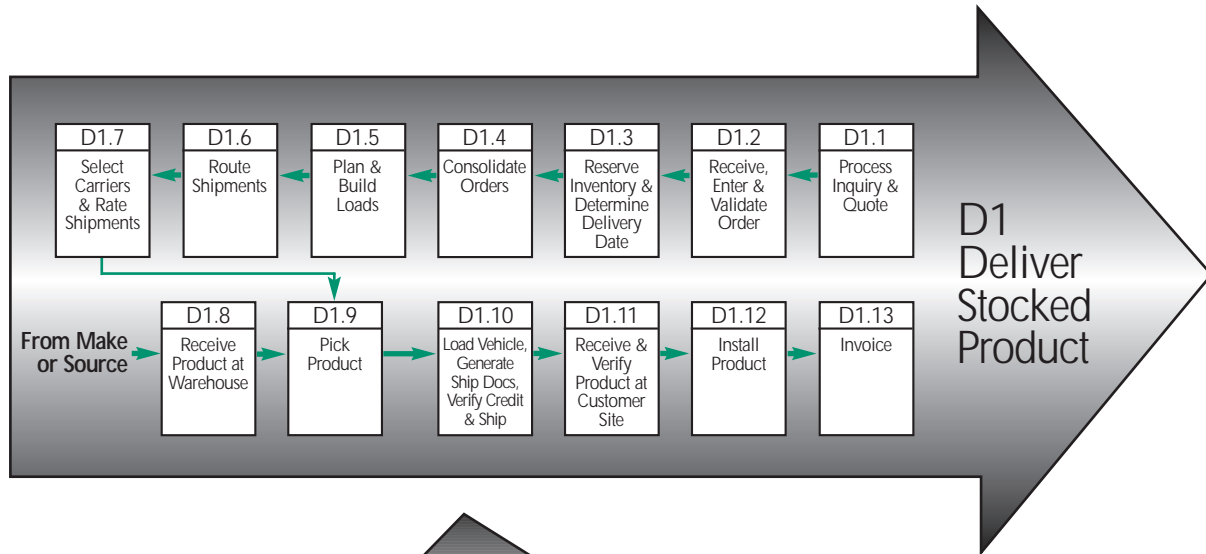
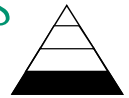

The Concept of “Configurability”

A supply-chain configuration is driven by:

- ▶ **Plan** levels of aggregation and information sources
- ▶ **Source** locations and products
- ▶ **Make** production sites and methods
- ▶ **Deliver** channels, inventory deployment and products
- ▶ **Return** locations and methods

SCOR must accurately reflect how a supply-chain’s configuration impacts management processes and practices.

Each Basic Supply-Chain is a “Chain” of Source, Make, and Deliver Execution Processes

Configurability

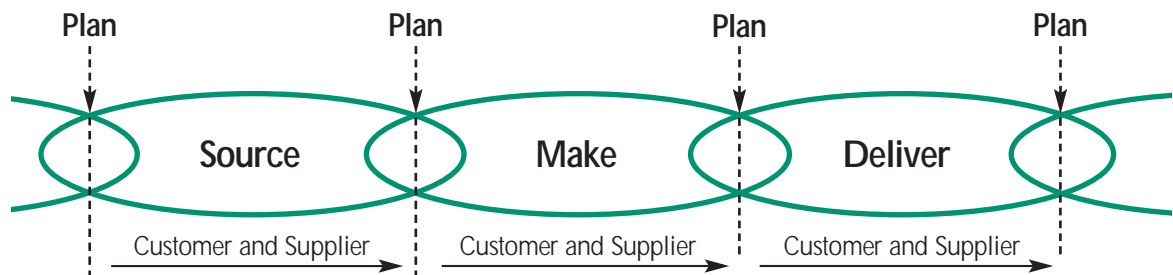

Each intersection of two execution processes (Source-Make-Deliver) is a “link” in the supply chain

- ▶ Execution processes transform or transport materials and/or products
- ▶ Each process is a customer of the previous process and a supplier to the next

Planning processes manage these customer-supplier links

- ▶ Planning processes thus “balance” the supply chain
- ▶ Every link *requires* an occurrence of a plan process category

How SCOR Logic Supports Horizontal Process Integration

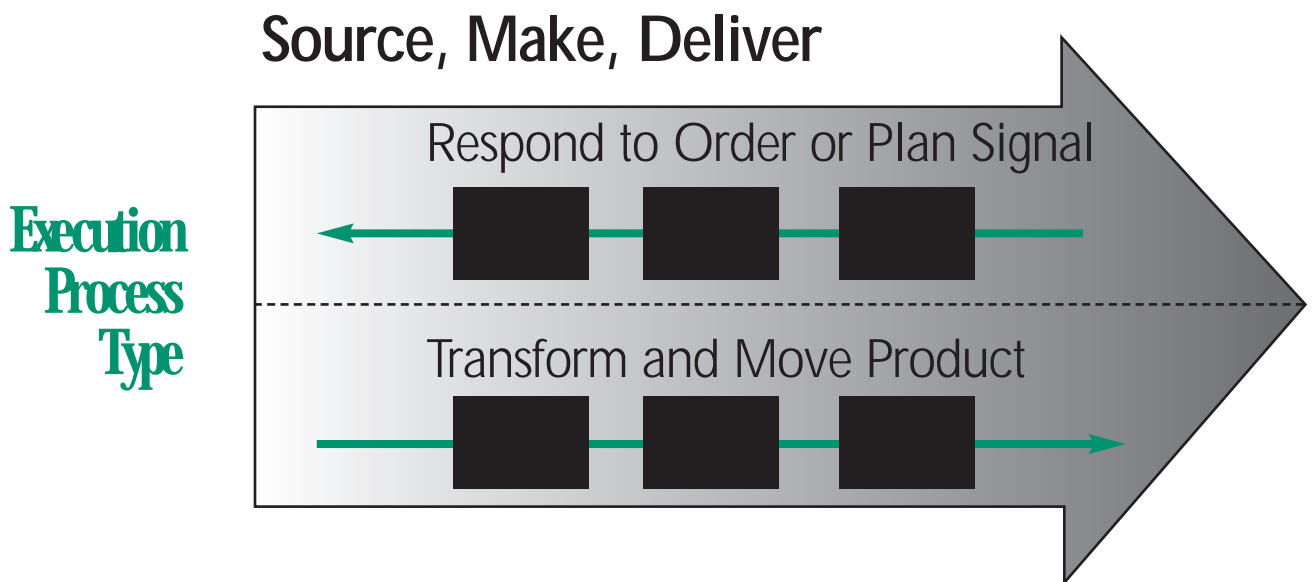
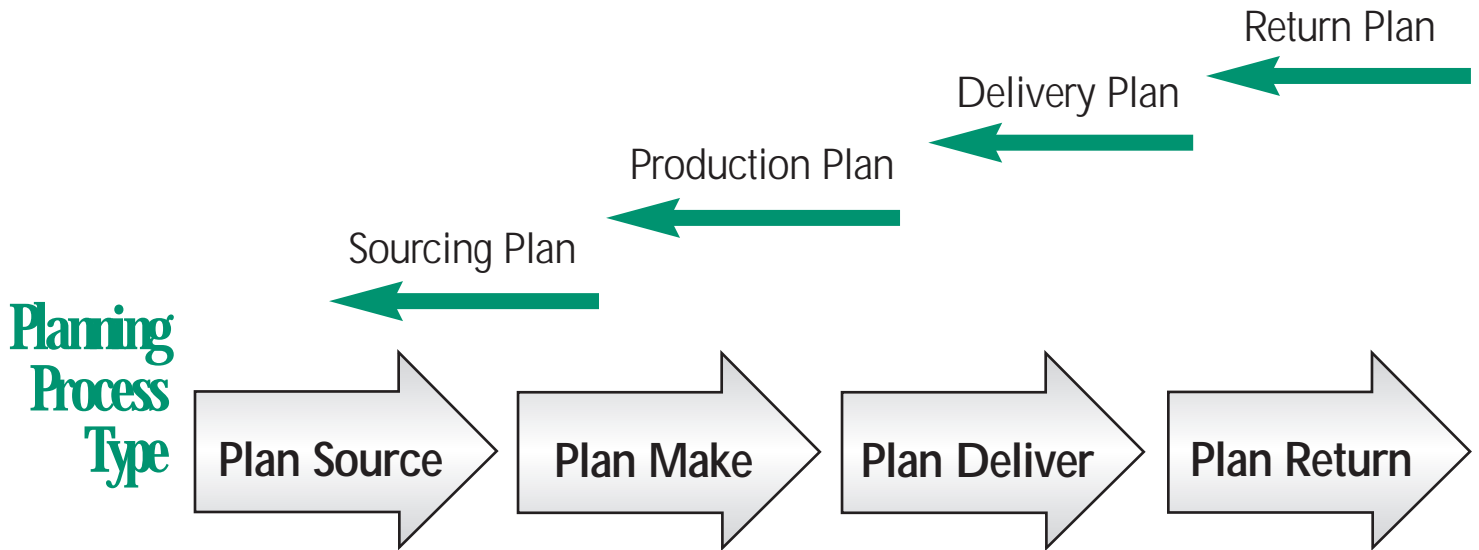

How SCOR Describes One SCM Trade-off

Make-to-Stock Configuration

Common SCM objective — achieve “market-winning” fulfillment time with the least inventory risk. *Example:* “pure” make-to-stock configuration. Plan Deliver and Deliver activities are taken upon receipt of Customer Order.

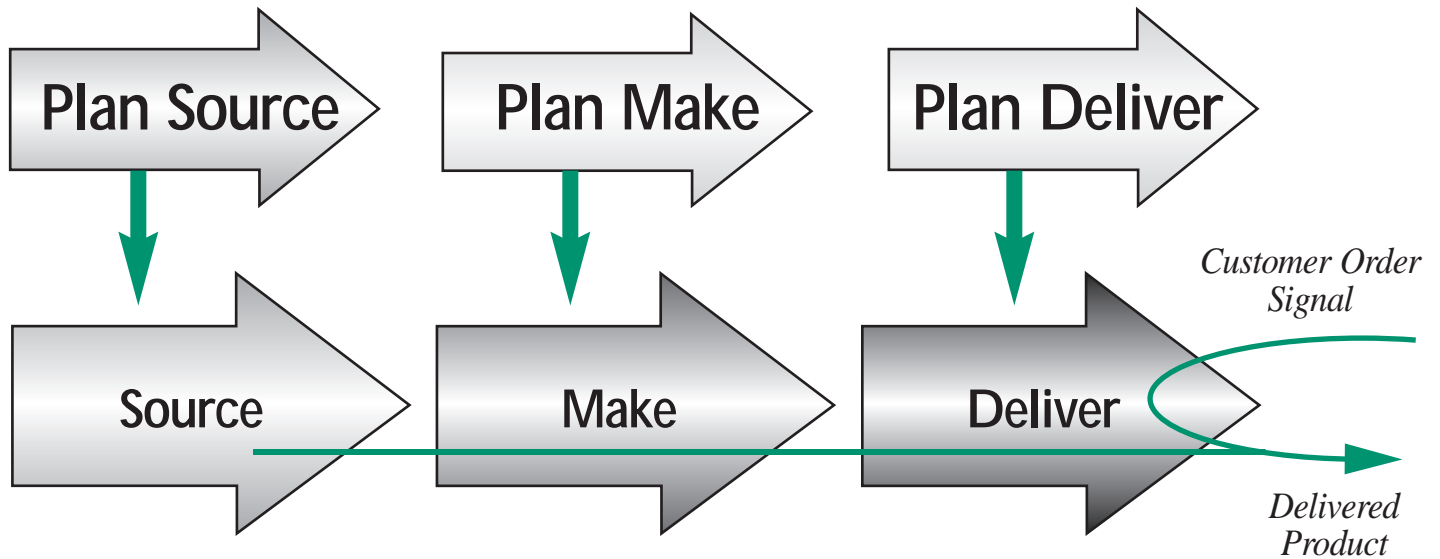

Common SCM objective — achieve “market-winning” fulfillment time with the least inventory risk. *Example:* replenish-to-order Deliver network. Plan Deliver activities are already in place and ready to be executed when Customer Order Signal is received.

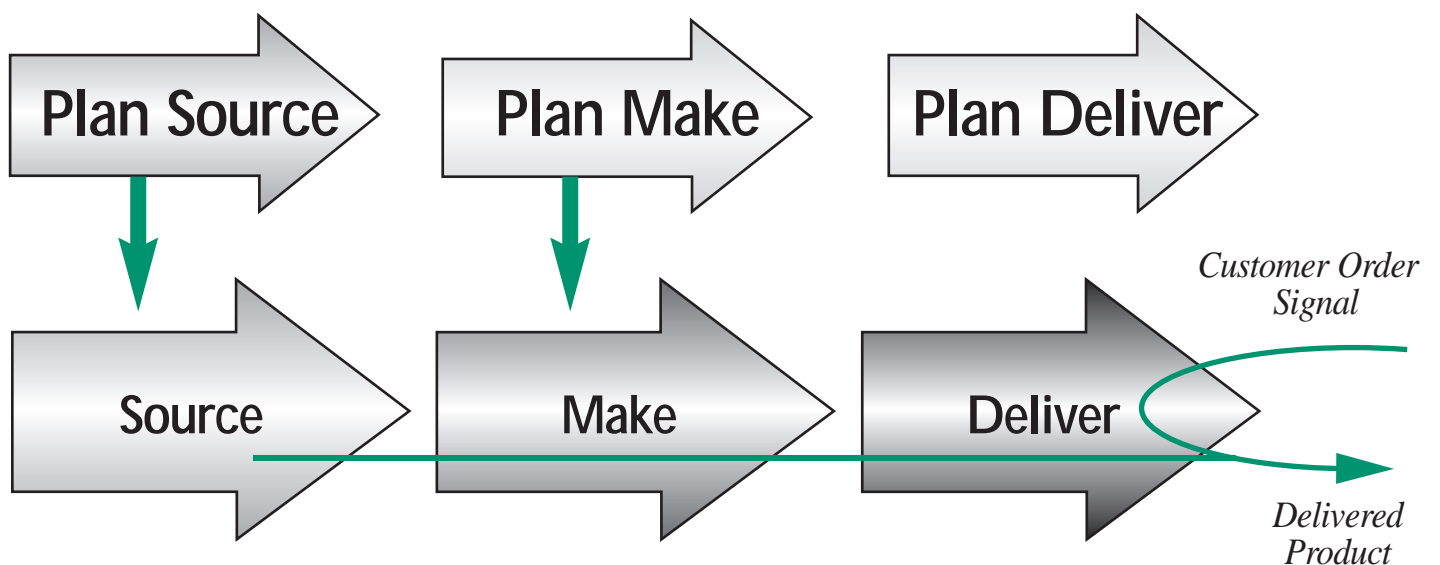

How SCOR Describes One SCM Trade-off

Make-to-Order Configuration

Common SCM objective — achieve “market-winning” fulfillment time with the least inventory risk. *Example:* make-to-order configuration. Plan Make and Plan Deliver activities are already in place and ready to be executed when Customer Order Signal is received.

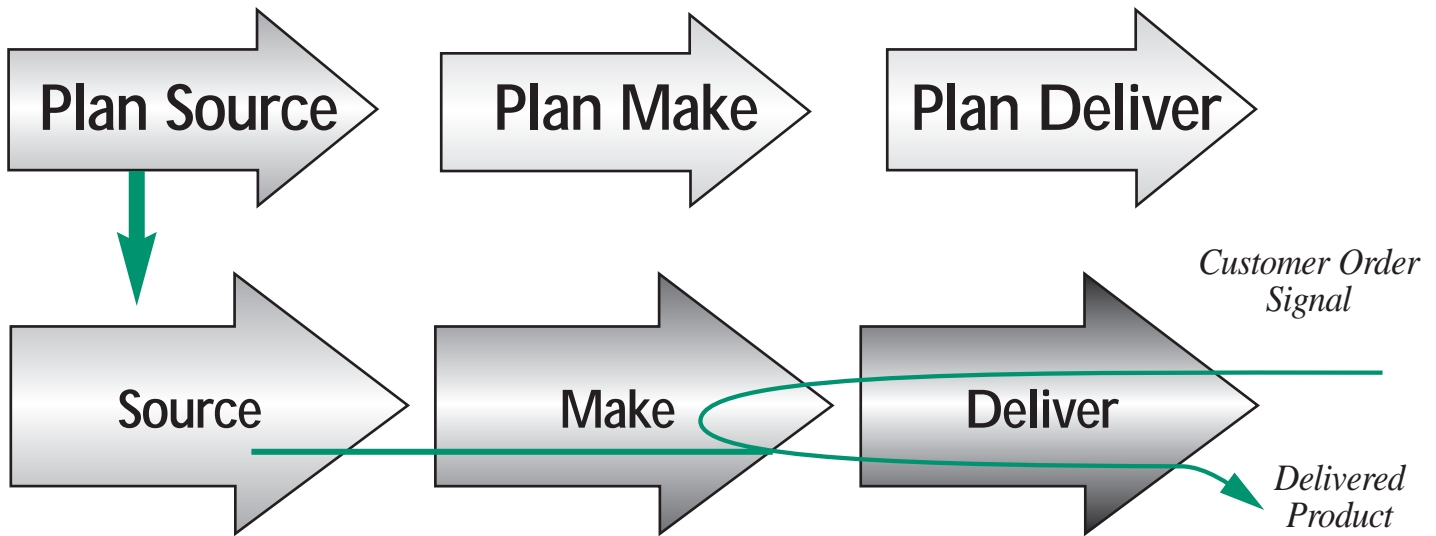

Common SCM objective — achieve “market-winning” fulfillment time with the least inventory risk. *Example:* make-to-order configuration that extends through the Source process. All inter-enterprise planning functions are already in place and ready to be executed when Customer Order Signal is received. This scheme requires some degree of intra-enterprise P1 Planning. *See page 23.*

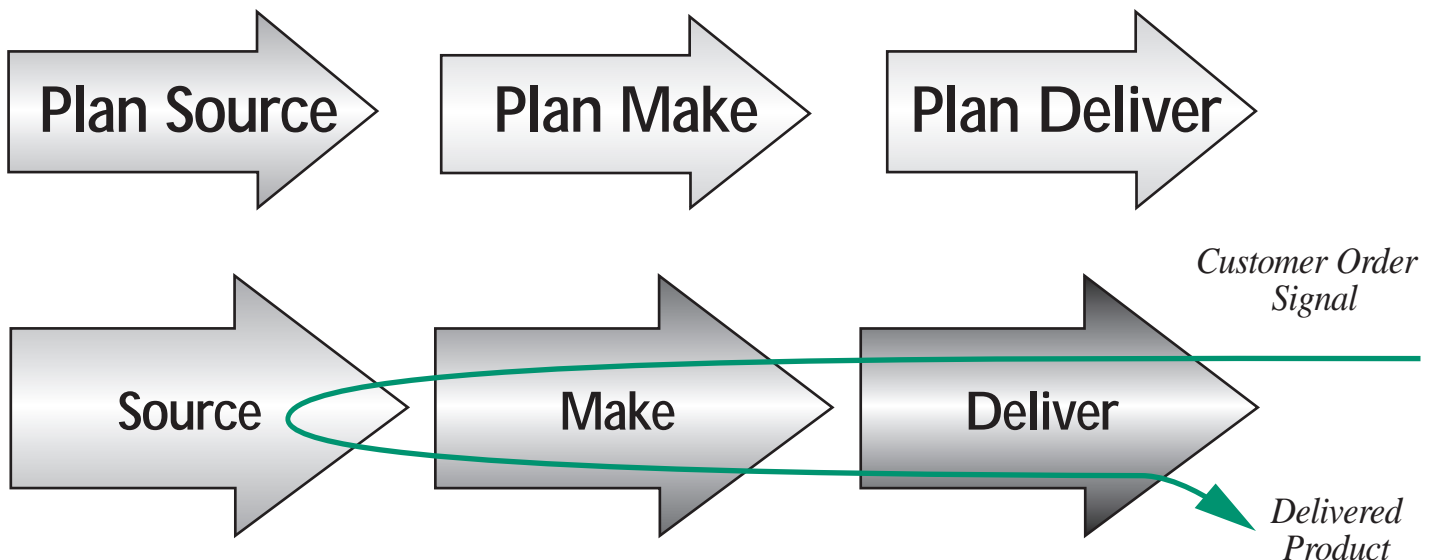

Configuring Supply-Chain Threads

Configuring a supply-chain “thread” illustrates how SCOR configurations are done. Each thread can be used to describe, measure, and evaluate supply-chain configurations.

1. Select the business entity to be modeled (geography, product set, organization)
2. Illustrate the physical locations of:
 - ▶ Production facilities (Make)
 - ▶ Distribution activities (Deliver)
 - ▶ Sourcing activities (Source)
3. Illustrate primary point-to-point material flows using “solid line” arrows
4. Place the most appropriate Level 2 execution process categories to describe activities at each location

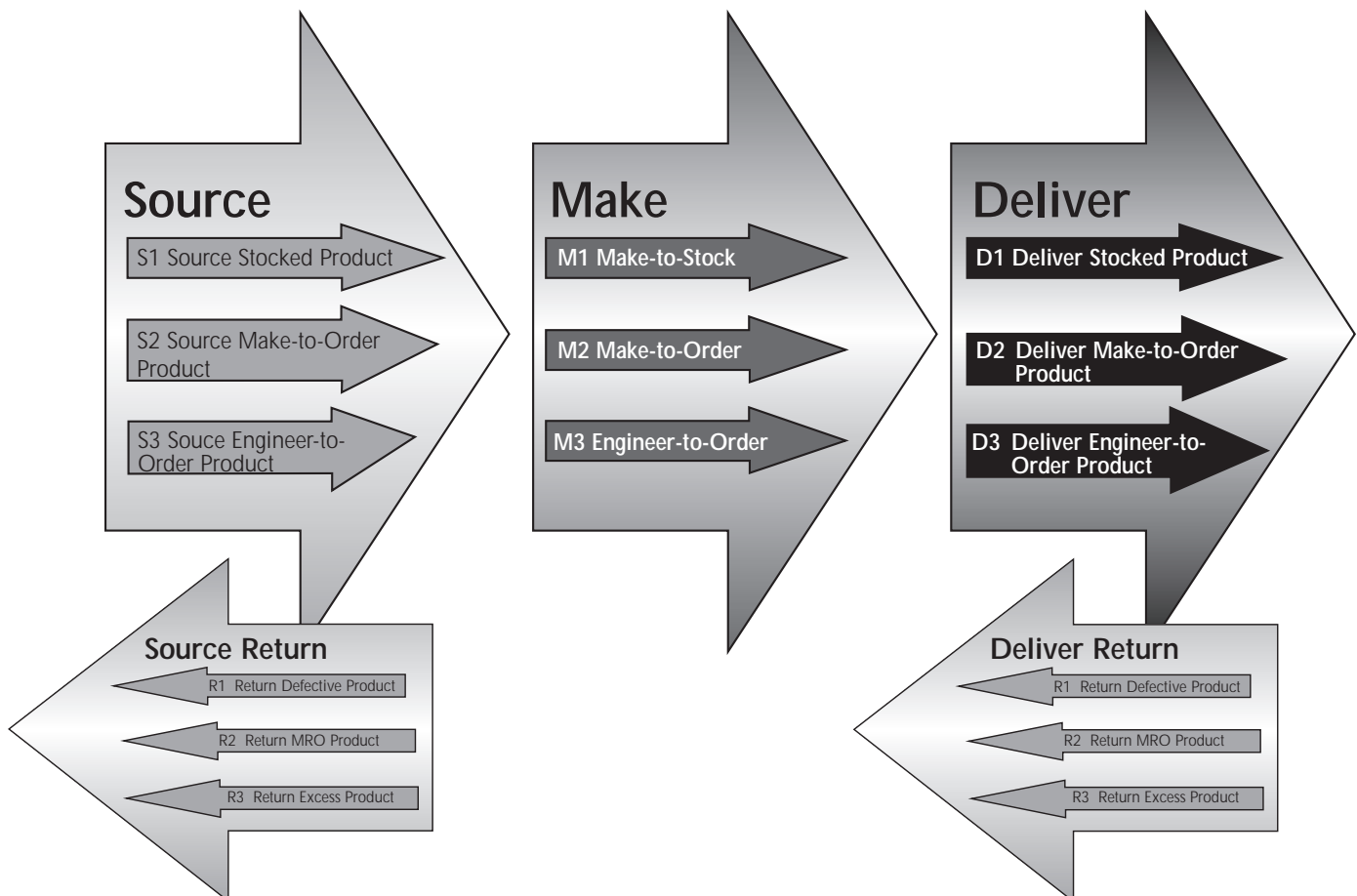

Supply Chain Threads are Developed from the Geographic Product Flow

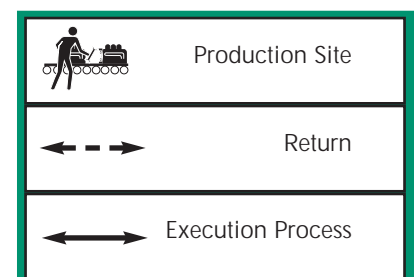
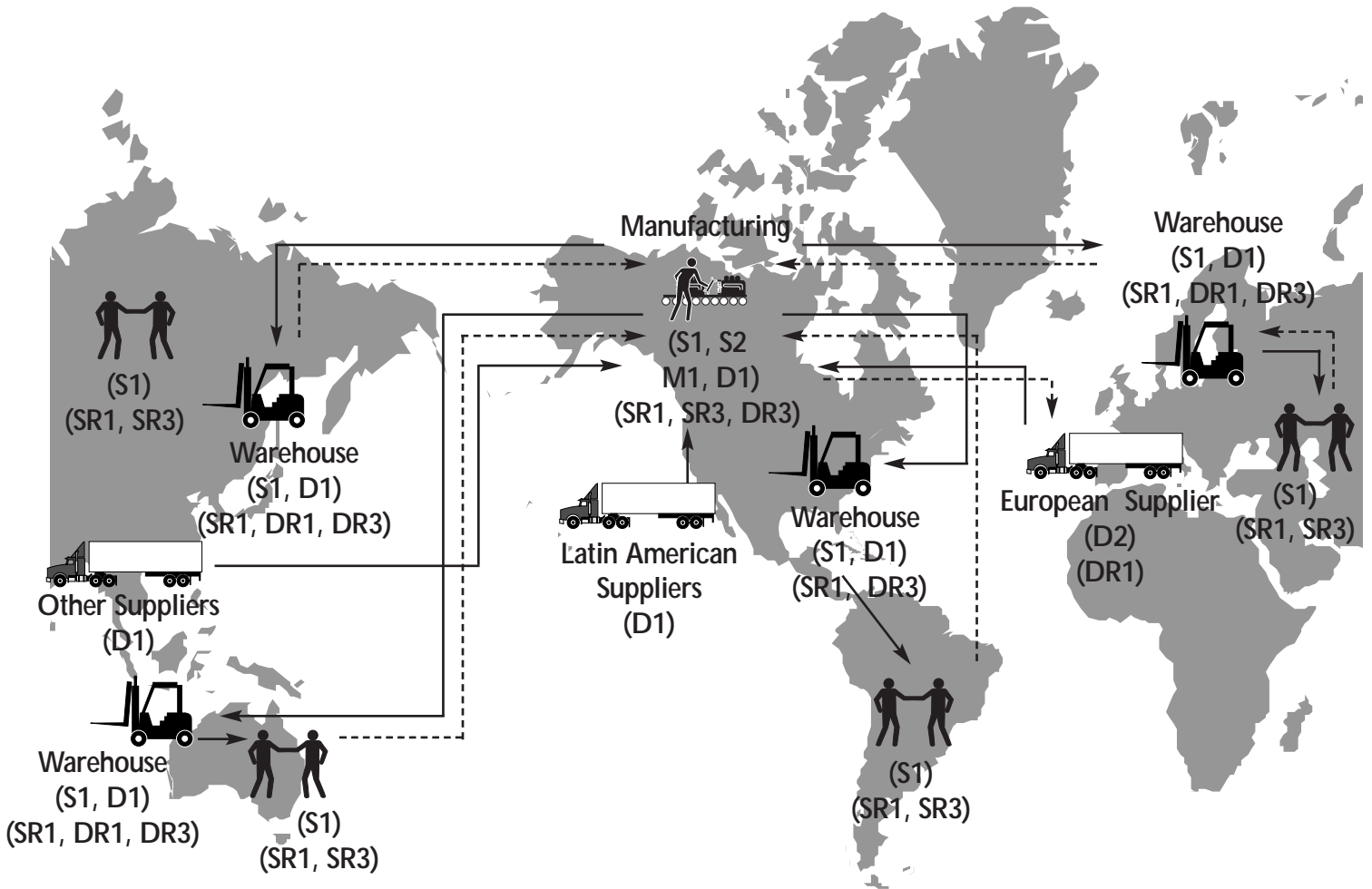

SCOR Process Maps are Used as a Basis for Evaluating/Understanding the Supply Chain

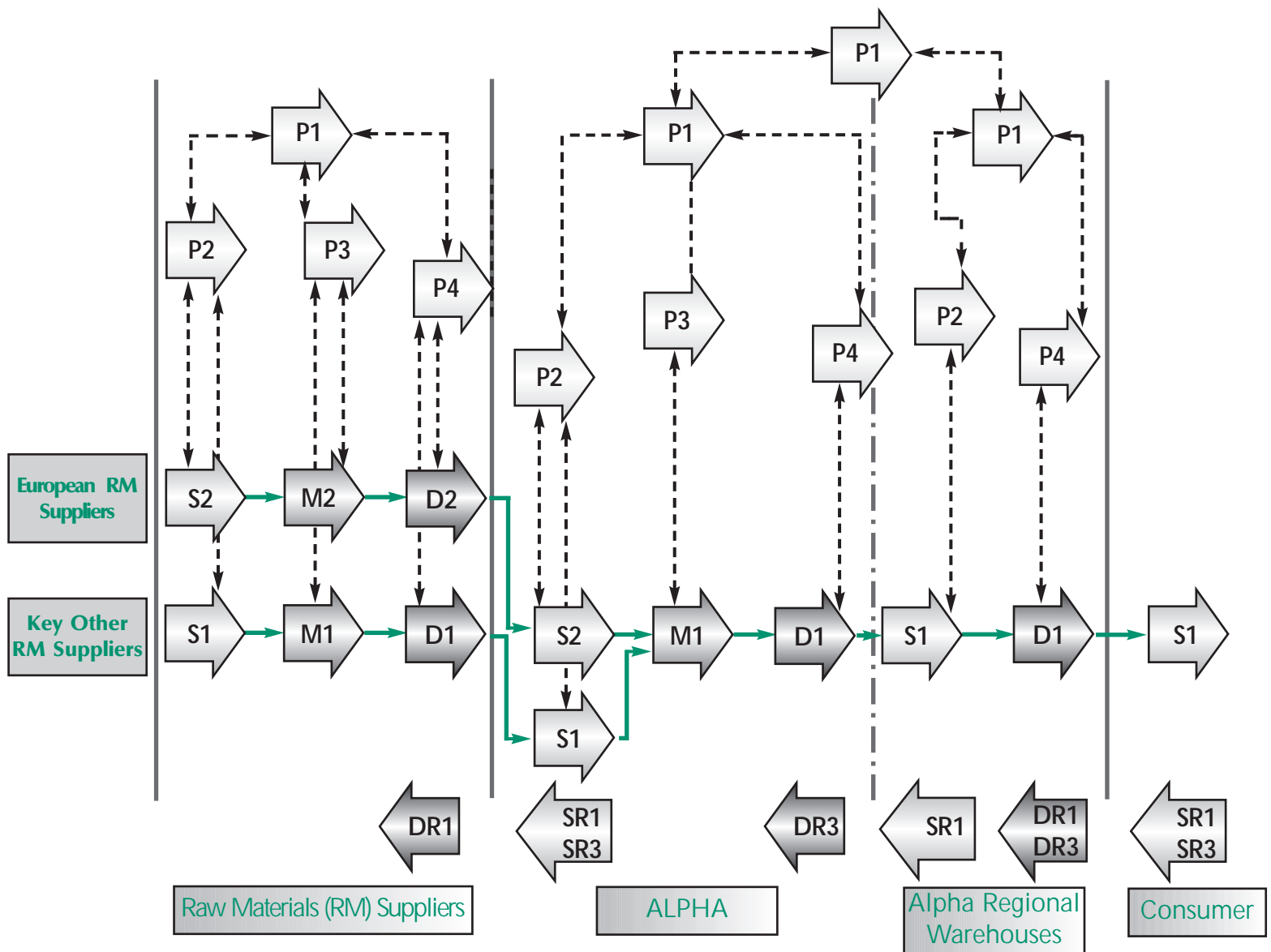

5. Describe each distinct supply-chain “thread”

- A supply-chain thread ties together the set of Source-Make-Deliver supply-chain processes that a given product family flows through
- Develop each thread separately to understand common, and distinct, execution and return process categories
- Consider end-to-end threads in the inter-company case

6. Place planning process categories, using dashed lines to show links with execution processes

7. Place P1, if appropriate

- P1 - Plan Supply Chain aggregates outputs from P2, P3, and P4

In a Classic Logistics World

A change in a supply chain often “ripples” through each linkage, affecting other areas.

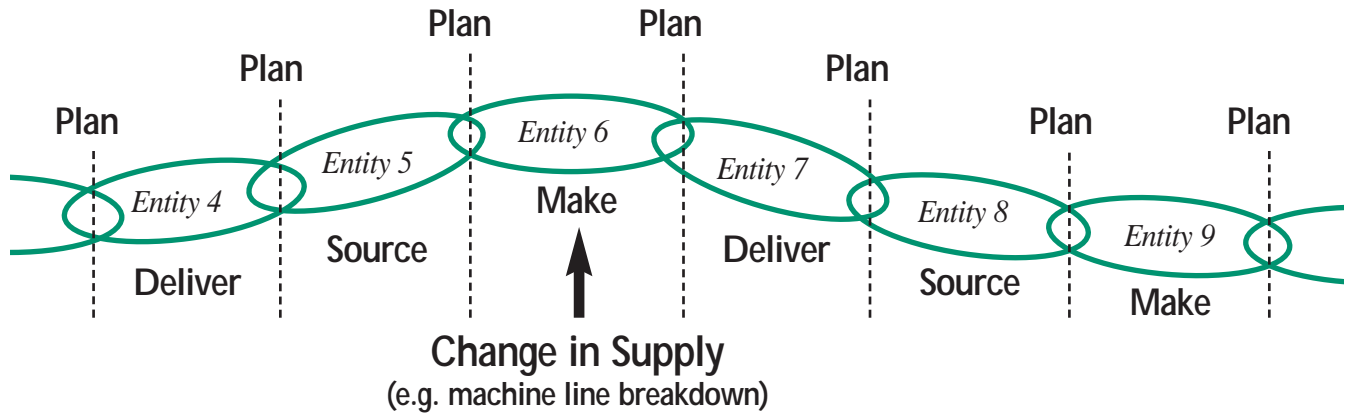

The impact of a change can be felt both up and down the supply chain

- ▶ A change in supply caused by a “production planner” may impact a “materials planner” and an “inventory planner”
- ▶ Further, such a change may impact both your customer’s and supplier’s supply-chain planning

Effective Supply-Chain Management Requires Balancing Multiple Links Concurrently

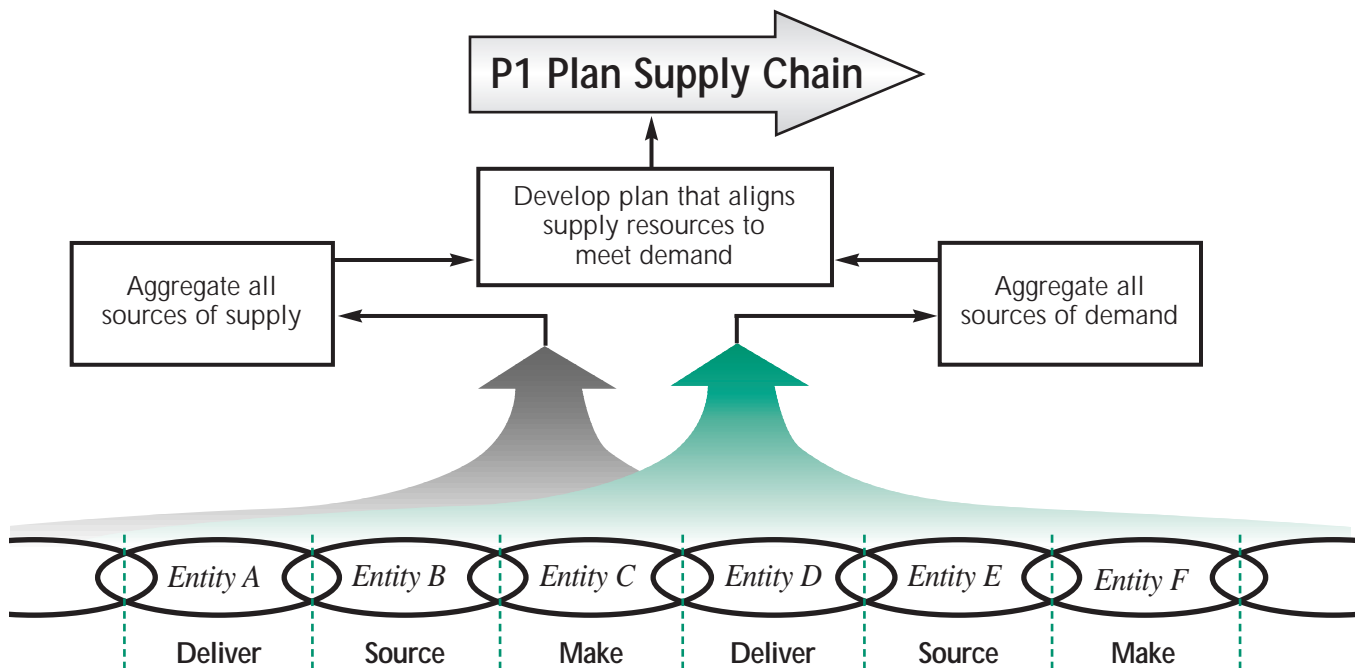



SCOR Overview

Summary

SCOR is a process reference model designed for effective communication among supply-chain partners.

- A standard *language* helps management to focus on management issues
- As an industry *standard*, SCOR helps management focus across inter-company supply chains

SCOR is used to *describe, measure and evaluate* Supply-Chain configurations

- **Describe:** Standard SCOR process definitions allow virtually any supply-chain to be configured.
- **Measure:** Standard SCOR metrics enable measurement and benchmarking of supply-chain performance.
- **Evaluate:** Supply-chain configurations may be evaluated to support continuous improvement and strategic planning.